

**Main Components**

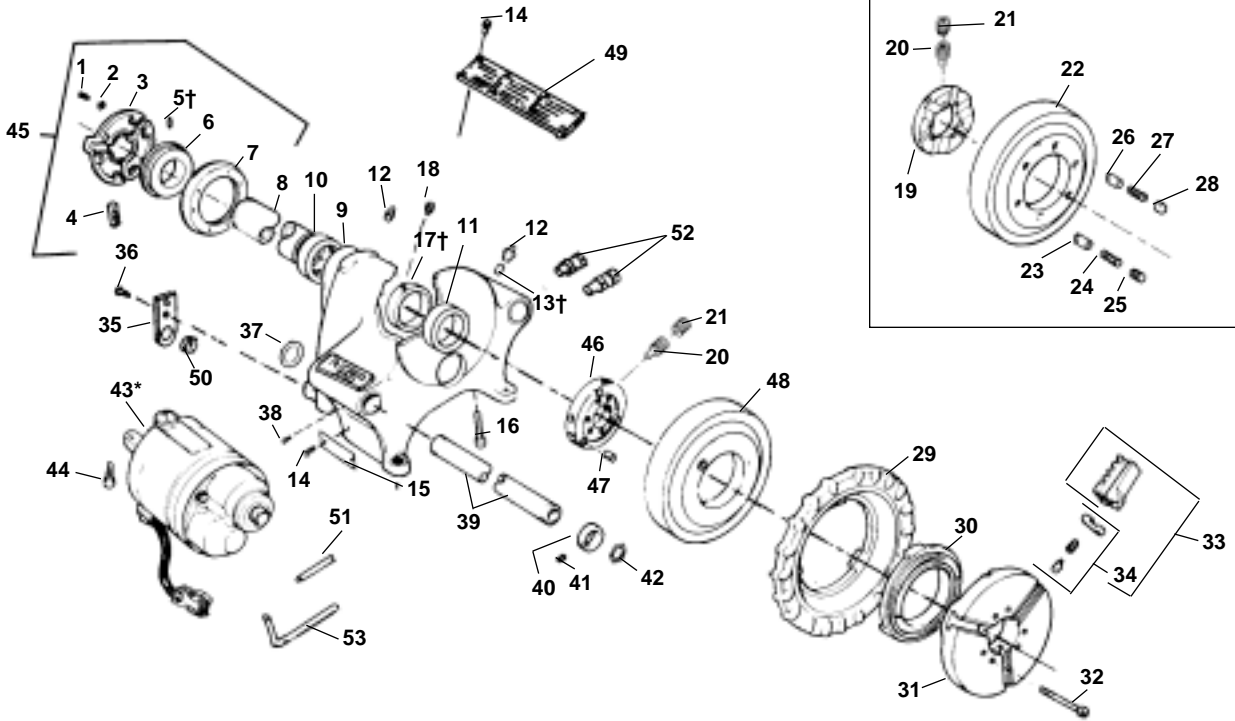

**NOTE: Order parts by Catalog Number only.  
DO NOT order by Reference Number.**

**For Information on Cutters, Die Heads and Reamers SEE INDEX**

Ref. No.	Catalog No.	Description	Ref. No.	Catalog No.	Description
1	46790	Screw, 12 - 24 x 3/4" (6)	27	44310	Drive Spring (3)
2	40270	Lock Washer (6)	28	45245	Drive Cap (3)
3	43735	Centering Head	29	89150	Hand Wheel
4	19346	Centering Head (Europe)	30	43540	Scroll
5	46500	Rear Jaw (3)	31	43525	Cap
6	45260	Step Pin (3)	32	45295	Screw 5/16" - 18 x 2 3/4" (6)
7	44095	Back Plate	33	44090	Chuck Jaw Set
8	43740	Back Plate (Europe)	34	44715	Jaw Insert Set
9	44100	Drive Shaft	35	97365	Jaw Insert Set F/Coated Pipe
10	42845	Body Assembly (Incl. Ref. No.10, 11, 12, 13, 14, 17, 18, 35, 36, 49, 50, 51, 52, 53)	36	45825	Strain Relief Plate
11	19056	Body Assy.- Europe (Incl. Ref. No.10, 11, 12, 13, 14, 17, 18, 35, 36, 49, 50, 51, 52, 53)	37	44735	Screw 1/4" - 20 x 5/8" (2)
12	45335	Rear Bearing-Bronze	38	44525	Spring Ring (2)
13	45270	Front Bearing-Bronze	39	45280	Screw #8 - 32 x 5/8" (2)
14	46860	Grease Fitting	40	44425	Support Bar (Incl. Ref. No. 37)
15	45310	Dowel Pin	41	44725	Ring Assembly (2) (Incl. Ref. No. 41, 42)
16	85920	Pop Rivet (10)	42	46050	Set Screw 1/4" - 18 x 1/4" (2)
17	90392	FOR/OFF/REV Label	43	44720	Snap Ring (2)
18	46035	Screw 5/16" - 18 x 1 3/4"	44	87740	Motor (115V) Std. 38 RPM
19	45345	Thrust Ring	45	87780	Motor (230V) Std. 38 RPM
20	33785	Set Screw 5/16" - 24 x 1/4" (2)	46	46745	Screw 3/8" - 16 x 1 1/4" (2)
21	44085	Pressure Ring	47	44165	Rear Centering Assembly
22	45265	Screw 5/16" - 24 x 1/2" (3)	48	30027	Drive Ring, Type II
23	45300	Screw 5/16" - 24 x 1/4" (3)	49	30022	Drive Pin, Type II (3)
24	43530	Ring Gear	50	30017	Ring Gear, Type II
25	45255	Pressure Plunger (3)	51	88690	Warning Plate
26	45285	Pressure Spring (3)	52	46735	Cord Grommet
27	45225	Pressure Plug (3)	53	96850	Tubing (300A)
28	45250	Drive Wedge (3)		96860	Bulkhead Union (2) (300A)
				96855	Tubing (300A)

\* Refer to Motor Model No. for Component Parts

**Service Notes:**

†Ref. 5 Stop Pins are easily removed by pushing from inside to outside.

†Ref. 13 Before removing front bearing sleeve (Ref. No. 11), dowel pin and grease fitting must be pushed out from inside.

†Ref. 17 Position thrust ring so that offset screw holes are closer to chuck.

**Electrical Components**

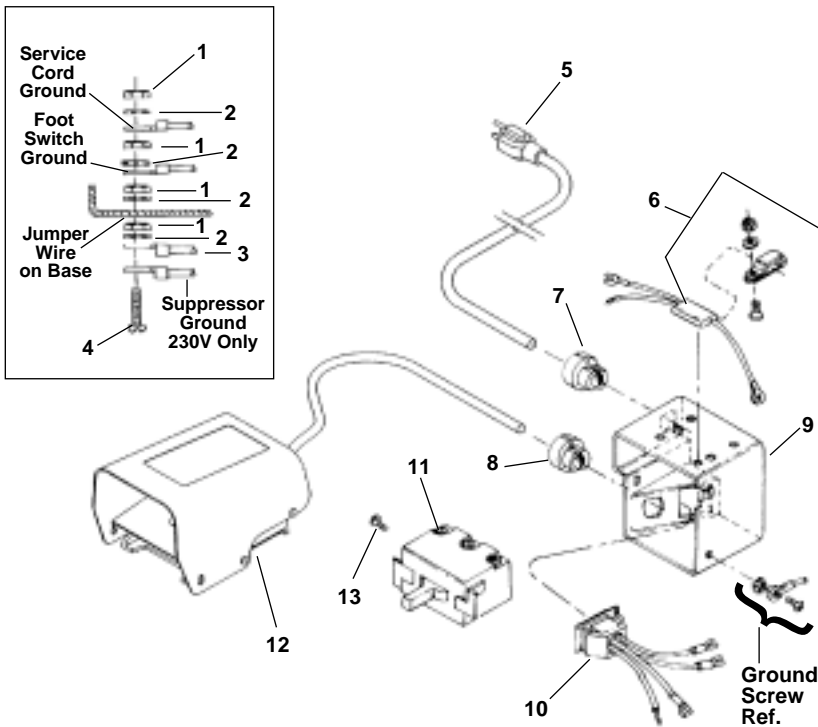

**NOTE: Order parts by Catalog Number only. DO NOT order by Reference Number.**

Ref. No.	Catalog No.	Description
1	44695	Hex Nut #10 - 24 (4)
2	46985	Ext. Tooth Washer #10 (4)
3	85925	Jumper Wire
4	92455	Screw #10 - 24 x 3/4"
5	46740	Power Cord w/Plug (115V)
	46410	Power Cord w/Plug (230V)
	75045	Power Cordless Plug (230V Europe/S. Africa)
6	46320	Suppressor Kit (230V Europe)
	99170	Suppressor (230V S. Africa)
7	46735	Cord Grommet
	46730	Cord Grommet (230V Europe/S. Africa)
8	46735	Cord Grommet
9	50612	Switch Box
10	50617	Outlet Jumper Assembly
11	44505	Switch
12	36642	B-294 Foot Switch
13	44180	Screw

**Wiring Diagram (115/230V)**

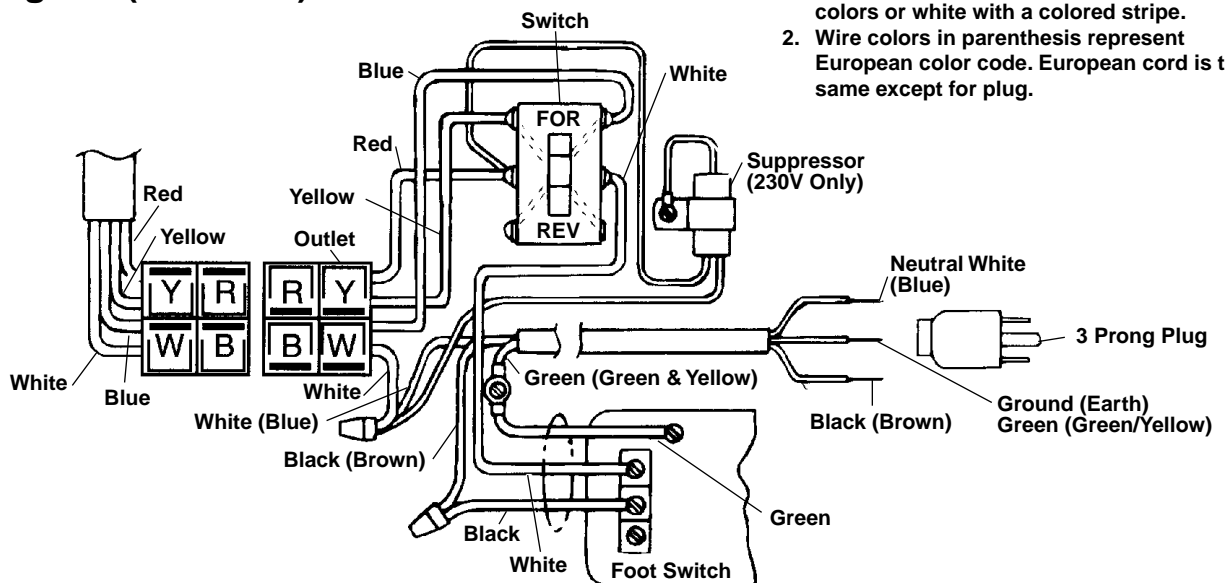

1. Brush and Armature Leads may be solid colors or white with a colored stripe.
2. Wire colors in parenthesis represent European color code. European cord is the same except for plug.

**European Electrical Components**

**NOTE: Order parts by Catalog Number only.  
DO NOT order by Reference Number.**

Ref. No.	Catalog No.	Description
1	63387	Brown Lead Wire
2	63392	Blue Lead Wire
3	62027	Quick Disconnect Terminal (4)
4	63372	Suppressor
5	92455	10 - 24 x 3/4" Screw
6	54222	Cord Clamp
7	44695	Nut
8	63417	Base
9	64067	Shield
10	64062	Bottom Cover
11	43362	"J" Clips (6)
12	54177	Strain Relief
13	36652	B- 296 Foot Switch Assembly
14	54157	Switch
15	64052	Switch Plate
16	64057	Switch Gasket
17	41597	12 - 24 x 3/4" Screw
18	57517	Switch Face Plate
19	61397	Switch Knob
20	64467	Cable Tie
21	46880	Plastic Tube
22	63377	Ferrite Bead

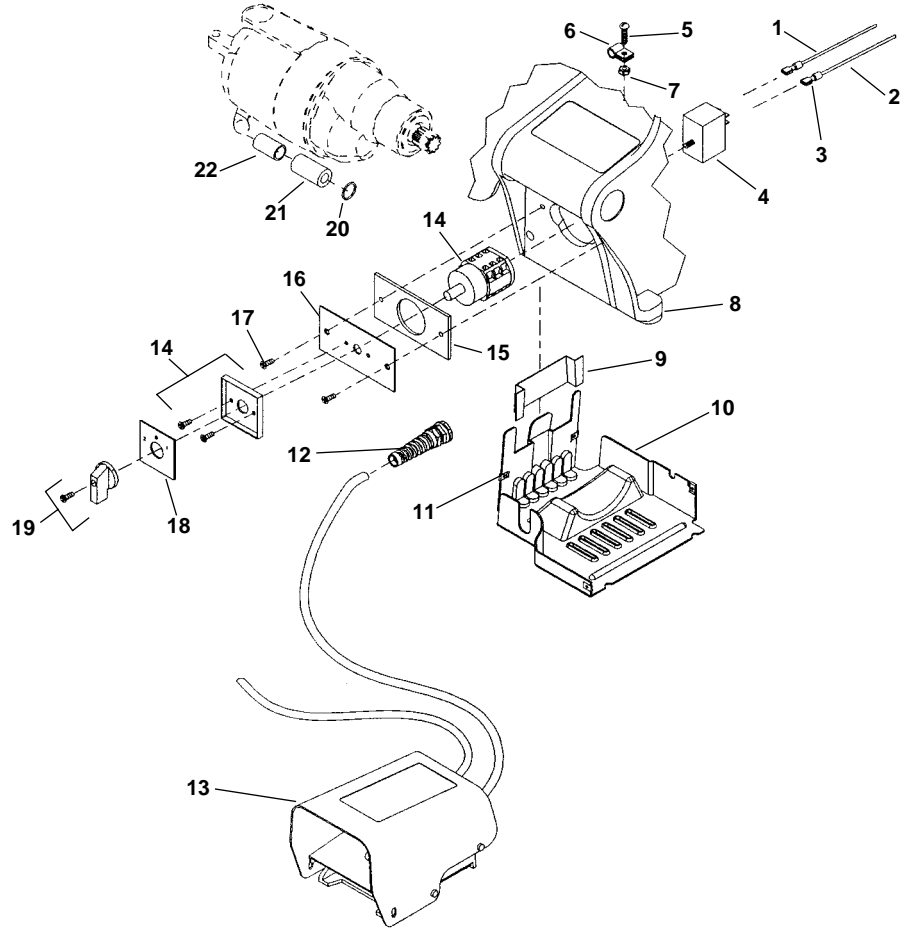

**Wiring Diagram – Europe**

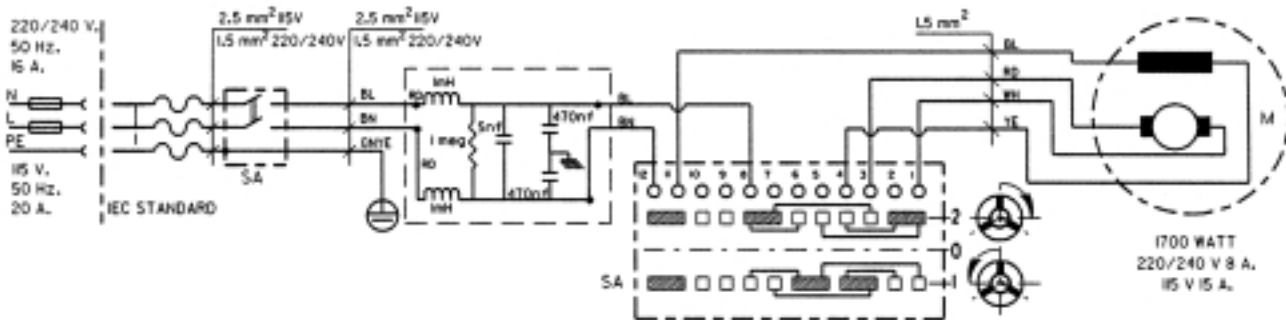

**3177**  
**3277**  
**3177-CE**  
**3277-CE**

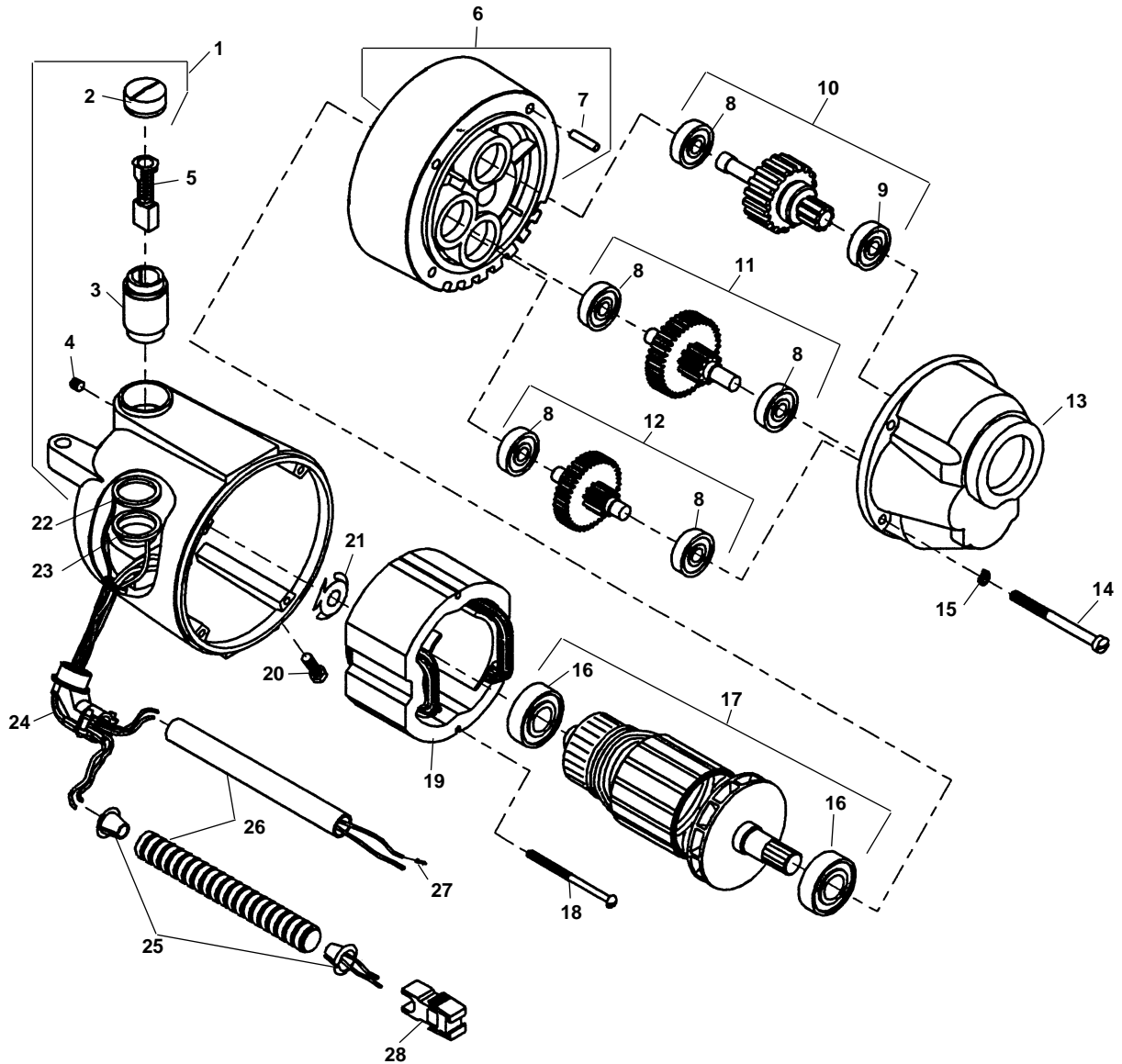

**NOTE: Order parts by Catalog Number only.  
 DO NOT order by Reference Number.**

Ref. No.	Catalog No.	Description	Ref. No.	Catalog No.	Description	Ref. No.	Catalog No.	Description
†	87740	3177 Motor 115V	10	45370	Drive Gear	20	83500	Locking Screw
†	87780	3277 Motor 230V	11	44985	1st Gear Assembly	21	44580	Loading Spring
†	61202	3177-CE Motor 115V	12	45005	2nd Gear Assembly	22	86680	White Upper Lead
†	61207	3277-CE Motor 230V	13	42875	Gear Housing	23	86685	Red Lower lead
1	43160	Housing Assembly		19066	Gear Housing (Europe)	24	46900	Connector 90 Degree
2	44545	Brush Cap Set	14	45075	Screw (4)	25	46890	E-918 Insulator (2)
3	45025	Brush Holder Set	15	45150	Lock Washer	26	47407	Flexible Conduit
4	39770	Set Screw (2)	16	44565	Armature Bearing (2)	27	46880	Plastic Tube (CE Only)
5	44540	Brush Assembly Set	17	44010	Armature (115V)	28	88402	Wire Terminal (4) (CE Only)
6	43165	Fan Housing Assembly		44030	Armature (230V)	29	50552	Plug
7	45165	Dowel Pin	18	44555	Mounting Screw (2)			
8	45060	Gear Bearings (5)	19	44015	Field (115V)			
9	45315	Front Bearing		44038	Field (230V)			

† Refer to Speed Change Chart for Optional Speeds on Page 28

**3181**  
**3281**  
**3181-CE**  
**3281-CE**

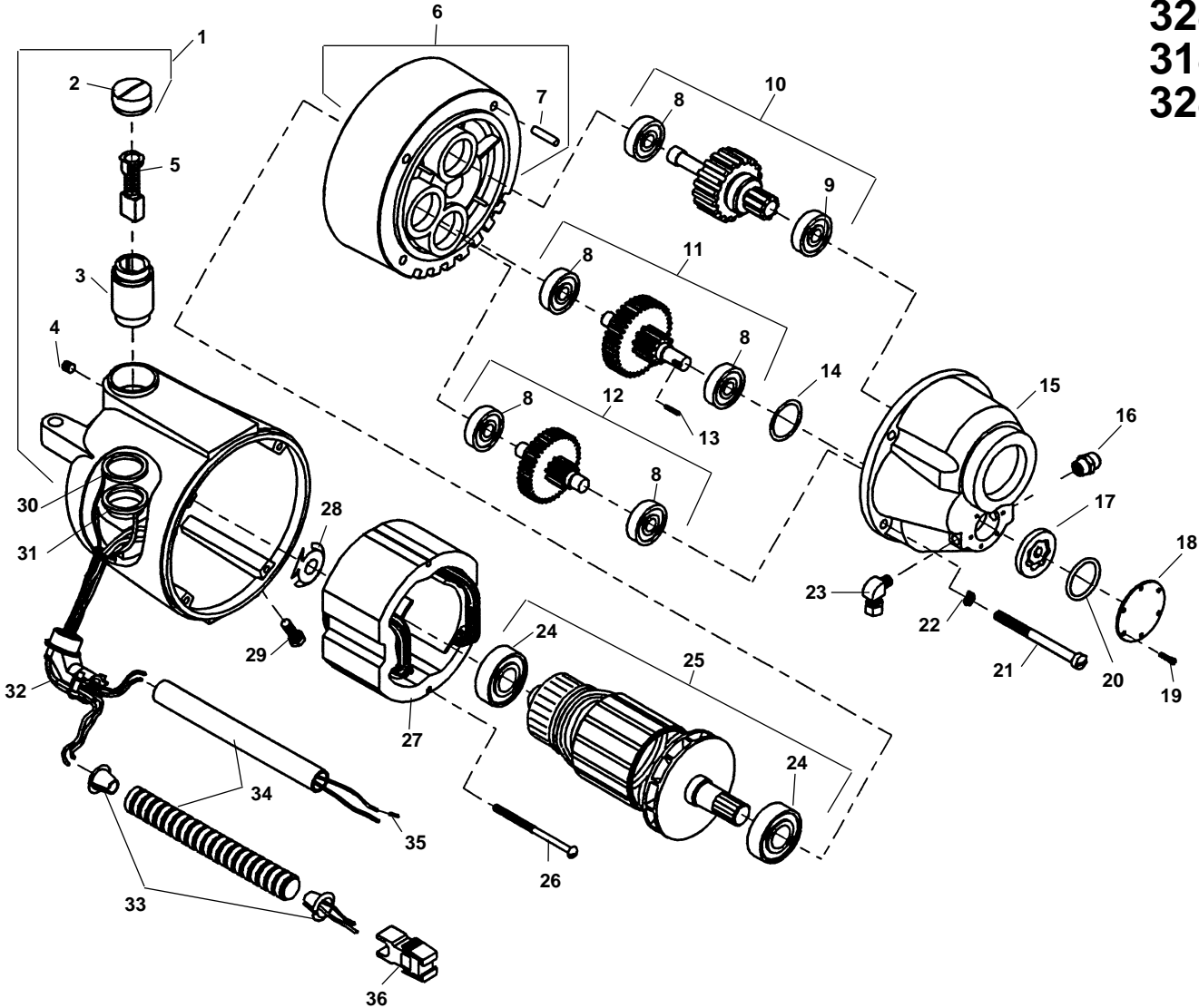

**NOTE: Order parts by Catalog Number only.  
 DO NOT order by Reference Number.**

Ref. No.	Catalog No.	Description	Ref. No.	Catalog No.	Description	Ref. No.	Catalog No.	Description
†	96810	3181 Motor 115V	12	45005	2nd Gear Assembly	26	44555	Mounting Screw (2)
†	96975	3281 Motor 230V	13	96885	Pin	27	44015	Field (115V)
†	61192	3181-CE Motor 115V	14	96880	Oil Seal		44035	Field (230V)
†	61197	3281-CE Motor 230V	15	96830	Gear Housing	28	44580	Loading Spring
1	43160	Housing Assembly	16	46830	Male Connector	29	83500	Locking Screw (2)
2	44545	Brush Cap Set	17	96870	Gerotor Set	30	86680	White Upper Lead
3	45025	Brush Holder Set	18	96840	Cover Plate	31	86685	Red Lower lead
4	39770	Set Screw (2)	19	96890	Screw (6)	32	46900	Connector 90
5	44540	Brush Assembly Set	20	96875	O Ring	33	46890	E-918 Insulator (2)
6	43165	Fan Housing Assembly	21	45075	Screw (4)	34	47407	Flexible Conduit
7	45165	Dowel Pin	22	45150	Lock Washer		46880	Plastic Tube (CE Only)
8	45060	Gear Bearings (5)	23	96910	Male Elbow	35	88402	Wire Terminal (4) (CE Only)
9	45315	Front Bearing	24	44565	Armature Bearing (2)	36	50552	Plug
10	45370	Drive Gear	25	44010	Armature (115V)			
11	97000	1st Gear Assembly		44030	Armature (230V)			

† Refer to Speed Change Chart for Optional Speeds on Page 28

**No. 309 Oil Spout (300A Power Drive)**

**309**  
**330**  
**331**

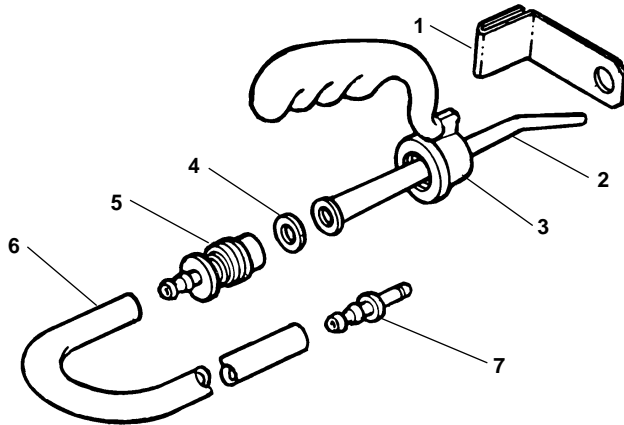

**NOTE: Order parts by Catalog Number only. DO NOT order by Reference Number.**

Ref. No.	Catalog No.	Description
—	97090	309 Oil Spout
1	97110	Spout Bracket Assembly
2	97095	Oil Spout
3	41690	Handle
4	41715	Spout Washer
5	97100	Handle Adapter
6	97195	Hose
7	97105	Hose Adapter

**No. 330 Oil Pan (300A Power Drive)**

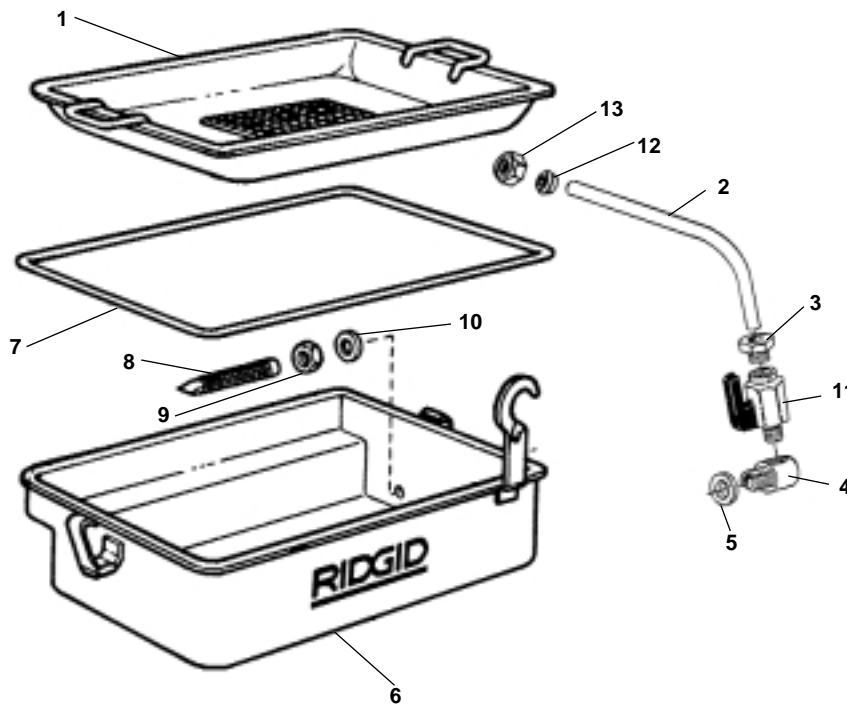

Ref. No.	Catalog No.	Description
—	97245	330 Oil Pan and Chip Tray
1	96925	Chip Pan Assembly
2	19946	300 Oil Line
3	96930	Union
4	41705	Coupling
5	41780	Washer
6	96920	Oil Pan Assembly
7	96905	Gasket
8	41765	Strainer
9	40640	Hex Jam Nut
10	41790	Washer
11	19936	Valve (Europe)
—	26846	Bolt (Europe) (Not Shown)
12	19966	Ferrule
13	19956	Nut

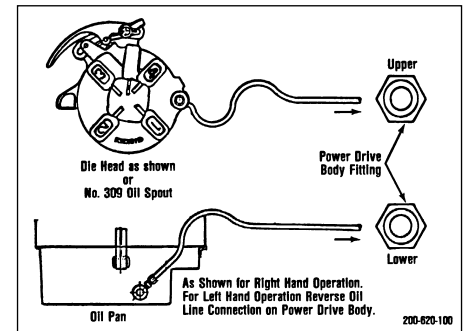

**No. 331 Oil Pan Support Tray**  
**Catalog No. 97250**  
**(300A Power Drive)**

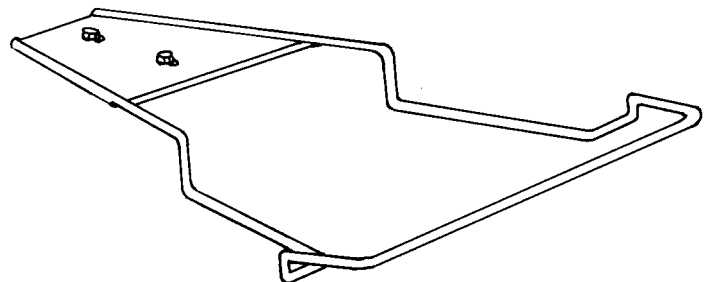

**No. 311 Carriage w/Lever** (200, 300 Power Drive)

**No. 311A Carriage w/Lever** (300A, 304 Retrofit)

**311**  
**311A**  
**341**  
**360**

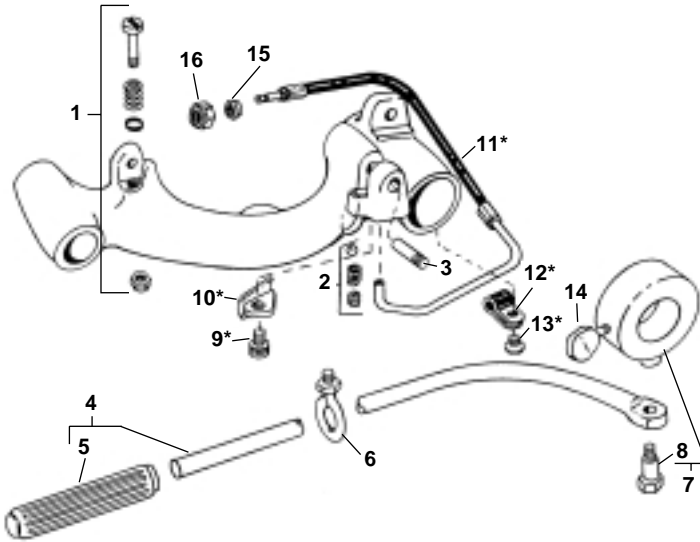

**NOTE: Order parts by Catalog Number only. DO NOT order by Reference Number.**

Ref. No.	Catalog No.	Description
—	68815	311 Carriage w/Lever
—	96945	311A Carriage w/Lever
—	42385	312 Lever Kit (incl. Ref. No. 4, 6, 7, 14)
1	45515	Stop Bolt Assembly
2	46810	Detente Assembly
3	47065	Reamer Hinge Pin
4	43400	Lever Arm Assembly
5	46235	Handgrip
6	46205	Eye Bolt Assembly
7	46215	Collar Assembly
8	46210	Shoulder Bolt
9	96900	Screw
10	96970	Oil Line Cover
11	96965	Hose Assembly
	19336	Hose Assembly (Europe)
12	96895	Clamp
13	96915	Screw
14	46220	Thumbscrew
15	19966	Ferrule
16	19956	Nut

**No. 341 Reamer**

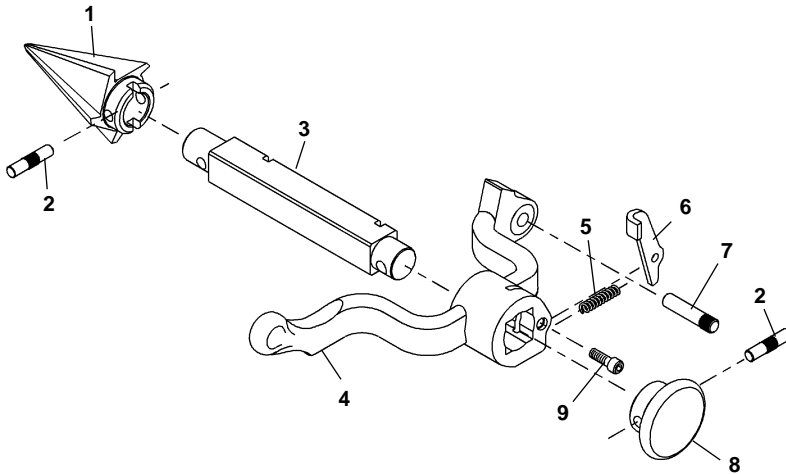

Ref. No.	Catalog No.	Description
—	42365	341 Reamer Complete
1	36277	Cone (R.H.)
	46660	Cone (L.H. & R.H.)
2	47155	F-693 Pin
3	43790	D-387 Reamer Bar
4	43230	C-144 Reamer Arm
5	44700	E-1664 Latch Spring
6	46665	E-865 Reamer Latch
7	47065	F-412 Hinge Pin
8	46585	E-762 Reamer Knob
9	46515	E-650 Screw 1/4" - 20 x 3/4"

**No. 360 Cutter**

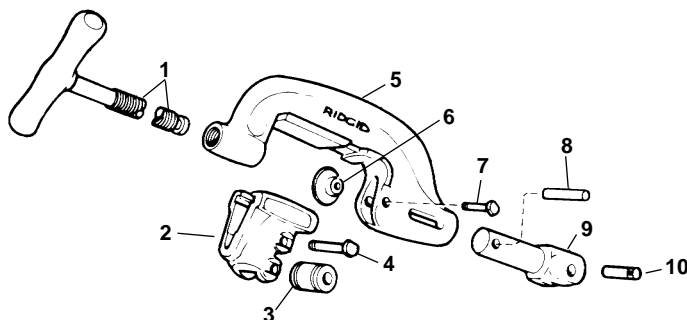

Ref. No.	Catalog No.	Description
—	42370	360 Cutter Complete
1	43625	D-1024-X Screw Handle
2	33400	C-878-X Roll Housing Assembly
3	34305	E-1751 Roll (2)
4	34310	E-1752 Roll Pin (2)
5	43595	C-877 Cutter Frame
6	33100	F-514 Cutter Wheel Thin
	33105	F-3 Cutter Wheel H.D.
	44185	E-1032 Cutter Wheel Std.
7	34780	F-9 Wheel Pin
8	45435	E-3549 Retaining Pin
9	45505	E-3759 Support Arm
10	45520	E-3819 Pin

**No. 32 Transporter**

**32**  
**1452**  
**1206**

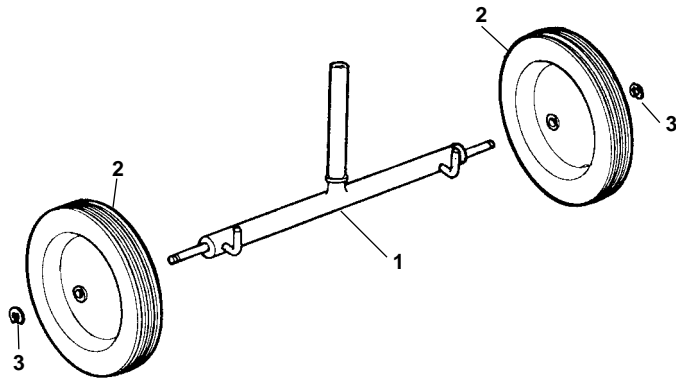

**NOTE: Order parts by Catalog Number only. DO NOT order by Reference Number.**

Ref. No.	Catalog No.	Description
—	42575	No. 32 Transporter
1	42590	Axle & Support Tube Assembly
2	42585	Wheel (2)
3	42580	Retaining Ring (2)

**No. 1452 Clip-On Tool Tray**

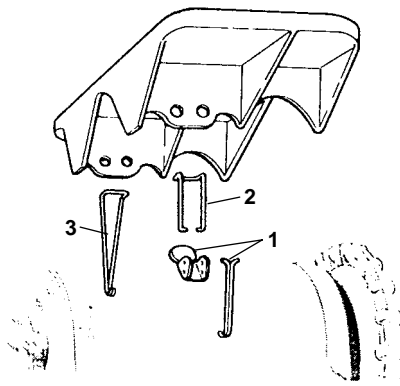

Ref. No.	Catalog No.	Description
—	42380	No. 1452 Tool Tray
1	45535	Hook & Lever Assembly
2	45540	Top Hook
3	45545	Side Hook

**No. 1206 Stand**

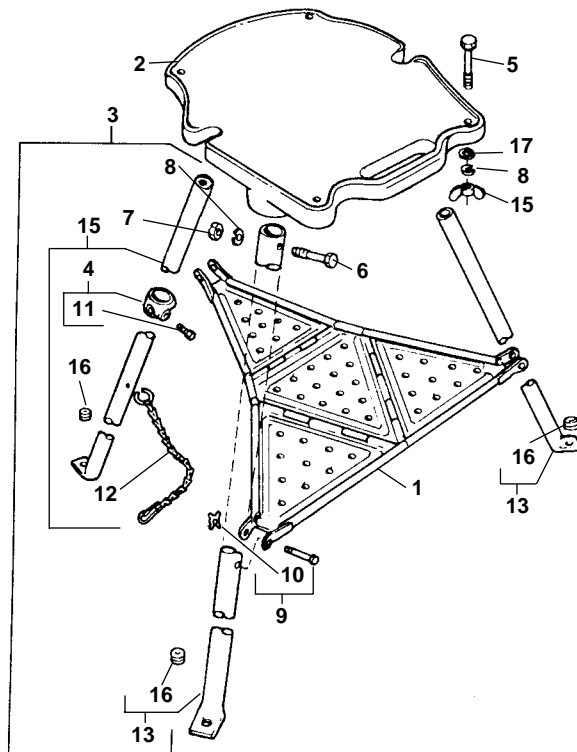

Ref. No.	Catalog No.	Description
—	42360	1206 Stand Complete
—	83540	1206 Stand Export
1	43475	B-547 Tool Tray
2	42870	B-1058 Base
3	42990	B-1983-X Tray & Leg Assembly
4	41235	D-488-X Tray Support
5	46670	E-867 Bolt $\frac{3}{8}$ " - 16 x 2" (4)
6	46675	E-868 Bolt $\frac{3}{8}$ " - 16 x 2 $\frac{3}{4}$ " (3)
7	44225	E-1094 Nut $\frac{3}{8}$ " - 16 (3)
8	40930	E-1095 Lock Washer $\frac{3}{8}$ " (7)
9	41265	E-1375-X Pin w/Washer (1 $\frac{7}{8}$ " Long)
	89720	E-10396-X Pin w/Washer (1 $\frac{5}{8}$ " Long)
10	41270	E-1377 X-Washer (6)
11	41245	E-1380 Set Screw $\frac{3}{8}$ " - 16 x 1"
12	40945	E-1444-X Chain Assembly
13	45325	E-1336-X Front Leg (2)
14	45330	E-3237-X Rear Leg
15	45385	E-3328 Wing Nut $\frac{3}{8}$ " - 16 (4)
16	40940	F-532 Grommet (3)
17	44230	E-1096 Washer $\frac{3}{8}$ " (4)



**SPEED CHANGE GEAR CHART  
MACHINE MODEL NO. 300 MOTORS**

Catalog No.	Model No.	Volts	Spindle Speed	Ref. #17 Armature	Ref. No. 11 - 1st Intermediate Gear Assembly	Ref. No. 12 - 2nd Intermediate Gear Assembly	Ref. No. 10 Drive Gear
87740 87780 61202 61207	3177 3277 3177-CE 3277-CE	115V 230V 115V 230V	38 STD.	Pinion - 14 T.	CAT. NO. 44985 (E-2600-X) 51 T. GEAR 12 T. PINION	CAT. NO. 45005 (E-2601-X) 42 T. GEAR 13 T. PINION	CAT. NO. 45370 (E-3283-X) 48 T.
87750 87790	3177A 3277A	115V 230V	57 STD.		CAT. NO. 44985 (E-2600-X) 51 T. GEAR 12 T. PINION	CAT. NO. 44990 (E-2601-AX) 42 T. GEAR 18 T. PINION	CAT. NO. 45375 (E-3284-X) 43 T.
87760 87800	3177B 3277B	115V 230V	77		CAT. NO. 44975 (E-2600-BX) 51 T. GEAR 15 T. PINION	CAT. NO. 44995 (E-2601-BX) 39 T. GEAR 18 T. PINION	CAT. NO. 45375 (E-3284-X) 43 T.
87770 87810	3177C 3277C	115V 230V	108		CAT. NO. 44980 (E-2600-CX) 51 T. GEAR 19 T. PINION	CAT. NO. 45000 (E-2601-CX) 35 T. GEAR 18 T. PINION	CAT. NO. 45375 (E-3284-X) 43 T.

**SPEED CHANGE GEAR CHART  
MACHINE MODEL NO. 300A MOTORS**

Catalog No.	Model No.	Volts	Spindle Speed	Ref. #17 Armature	Ref. No. 11 - 1st Intermediate Gear Assembly	Ref. No. 12 - 2nd Intermediate Gear Assembly	Ref. No. 10 Drive Gear
96810 96975 61192 91197	3181 3281 3181-CE 3281-CE	115V 230V 115V 230V	38 STD.	Pinion - 14 T.	CAT. NO. 97000 (E-2600-X) 51 T. GEAR 12 T. PINION	CAT. NO. 45005 (E-2601-X) 42 T. GEAR 13 T. PINION	CAT. NO. 45370 (E-3283-X) 48 T.
96815 96980	3181A 3281A	115V 230V	57 STD.		CAT. NO. 97000 (E-2600-X) 51 T. GEAR 12 T. PINION	CAT. NO. 44990 (E-2601-AX) 42 T. GEAR 18 T. PINION	CAT. NO. 45375 (E-3284-X) 43 T.
96820 96985	3181B 3281B	115V 230V	77		CAT. NO. 97005 (E-2600-BX) 51 T. GEAR 15 T. PINION	CAT. NO. 44995 (E-2601-BX) 39 T. GEAR 18 T. PINION	CAT. NO. 45375 (E-3284-X) 43 T.

**Stand Components**

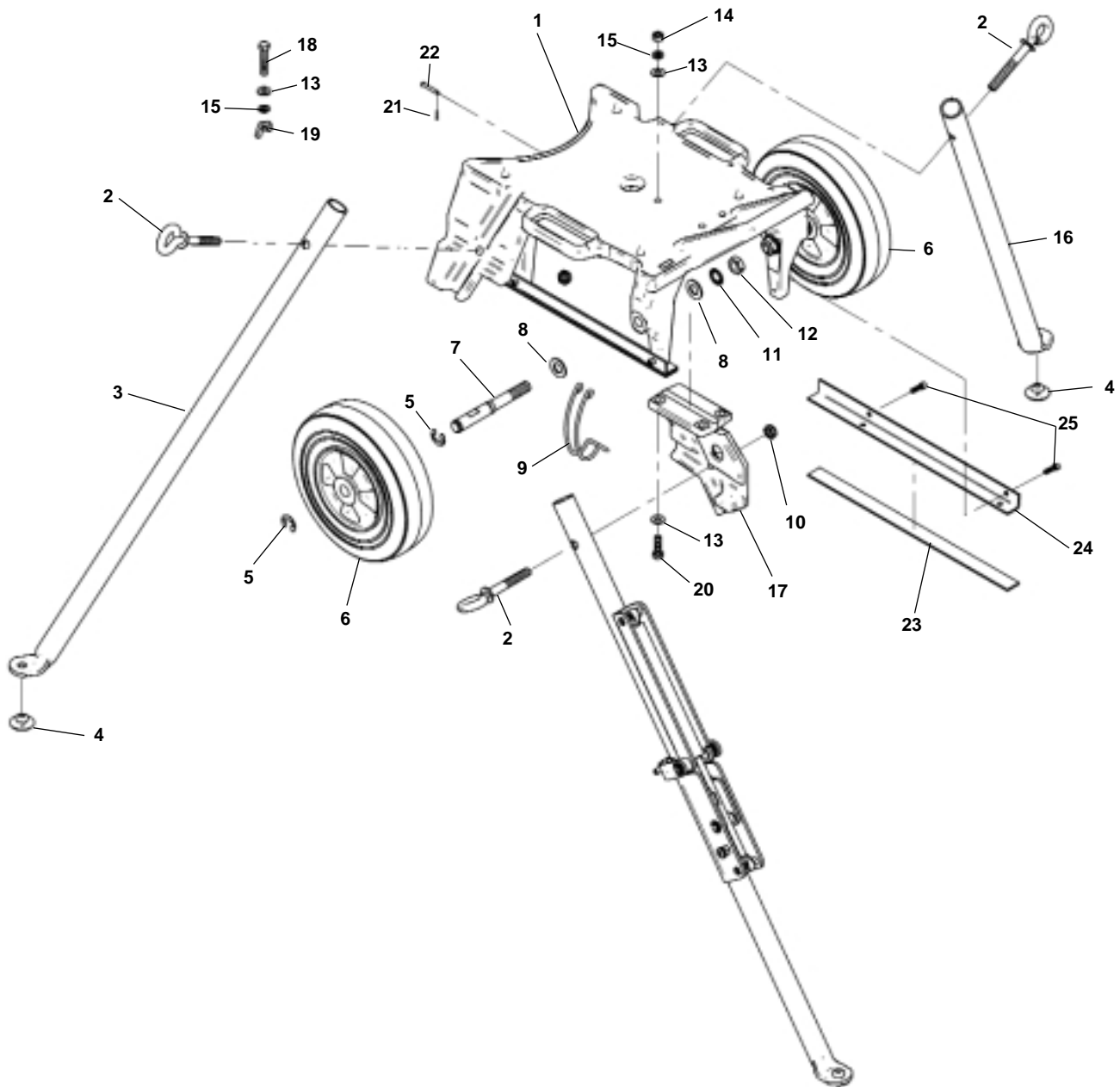

**NOTE: Order parts by Catalog Number only.  
DO NOT order by Reference Number.**

Ref. No.	Catalog No.	Description	Ref. No.	Catalog No.	Description
—	87342	300 Wheel-A-Way	13	90567	Washer (10)
1	90527	Base	14	90572	Hex Nut (3)
2	90532	Leg Bolt (3)	15	40930	Lock Washer (7)
3	90537	Leg, Front Left	16	90667	Leg, Front Right
4	90697	Leg Grommet (4)	17	90647	Rear Leg Mount
5	60050	Retaining Ring (4)	18	46670	Hex Bolt (4)
6	23602	Wheel (2)	19	45385	Wing Nut (4)
7	90542	Axle (2)	20	90672	Hex Bolt (3)
8	44042	Washer (4)	21	60055	Cotter Pin
9	90547	Leg Retention Hanger	22	90692	Clevis Pin
10	90552	Locknut (3)	23	90652	Skid Rail Pad
11	89515	Lock Washer (2)	24	90657	Skid Rail
12	60802	Jam Nut (2)	25	27357	Screw (4)

**Folding Leg Components**

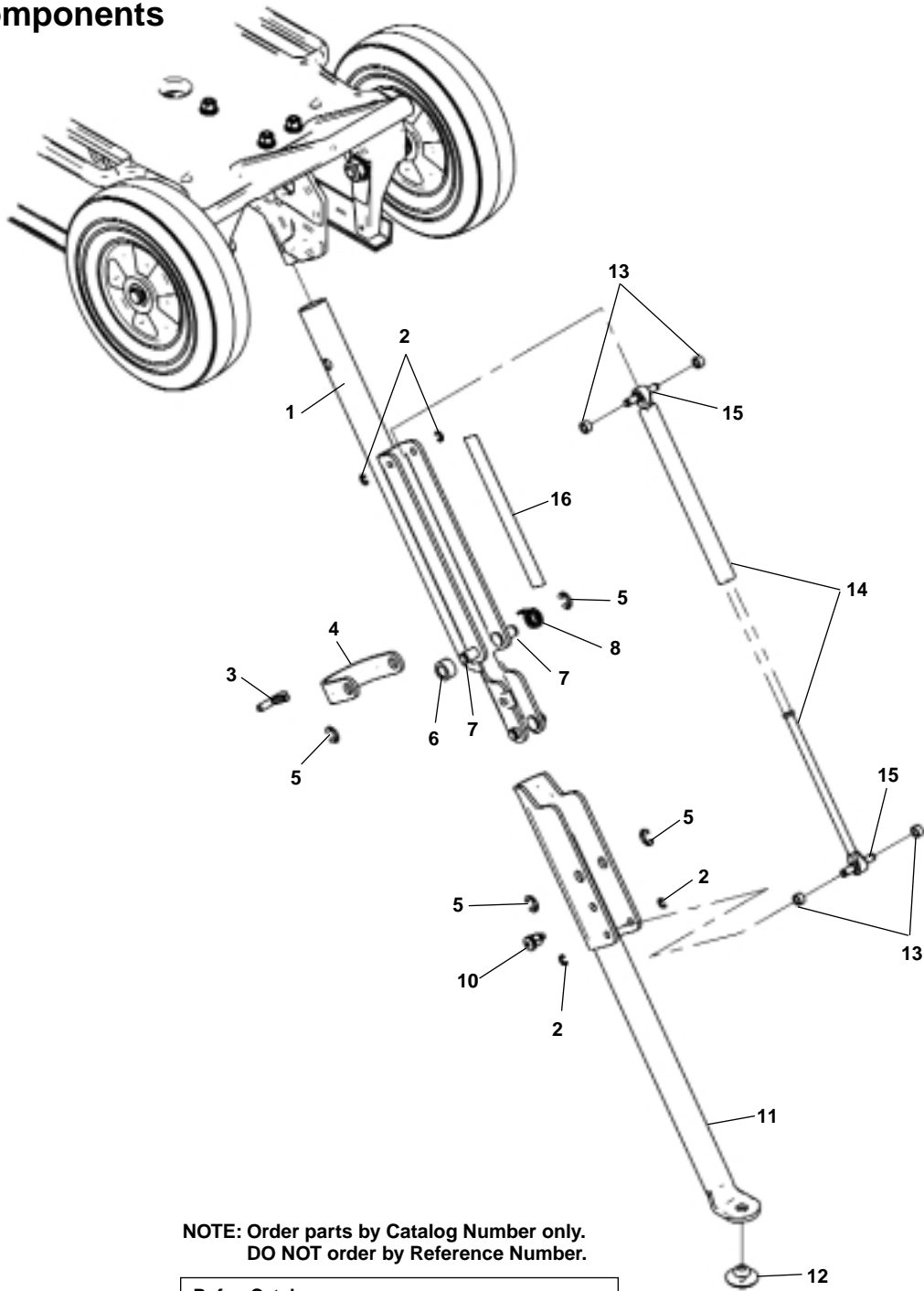

**NOTE: Order parts by Catalog Number only.  
DO NOT order by Reference Number.**

<u>Ref. No.</u>	<u>Catalog No.</u>	<u>Description</u>
1	90577	Upper Leg
2	34715	Retaining Ring (4)
3	90592	T-Stud
4	90587	Swivel Bracket
5	26937	Retaining Ring (4)
6	90602	Spacer
7	90607	Pivot Pin (2)
8	90612	Torsion Spring
9	90617	Pivot Pin (2)
10	90622	Plunger Pin
11	90627	Lower Leg
12	90697	Leg Grommet (4)
13	90632	Spacer (4)
14	90642	Gas Spring
15	90637	Pivot Pin (2)
16	90762	Warning Label